

## NEUTRON FILTER TECHNIQUE AND ITS USE FOR FUNDAMENTAL AND APPLIED INVESTIGATIONS

**O. Gritzay<sup>\*</sup>, V. Koloty, V. Pshenichnyi, M. Gnidak, O. Kalchenko, N. Klimova, V. Libman, V. Razbudey, A. Kyslytskyi, V. Venediktov, O. Korol**

*Institute for Nuclear Research, Prospekt Nauky, 47, Kyiv, Ukraine, 03680*

At Kyiv Research Reactor (KRR) the neutron filtered beam technique is used for more than 30 years and its development continues, the new and updated facilities for neutron cross section measurements provide the receipt of neutron cross sections with rather high accuracy: total neutron cross sections with accuracy 1% and better, neutron scattering cross sections with 3-6% accuracy. The main purpose of this paper is presentation of the neutron measurement techniques, developed at KRR, and demonstration some experimental results, obtained using these techniques.

**Keywords:** *research reactor, neutron filtered beam technique, neutron cross sections, ENDF/B libraries.*

### INTRODUCTION

Up-to-date level of scientific and technology development demands the high accuracy data on neutron interaction with nuclei and elements. High accuracy of experimental data should allow to make progress in development of nuclear simulation codes and in generation of evaluated nuclear data libraries, that are information basis for any transport calculations both for operating and future reactors and for nuclear technologies in medicine, industry, etc.

Now the most difficult situation with the accuracy of neutron cross sections is in the energy range from several keV to several hundred keV. The reason is in the lack of high flux installations, which can provide the measurements of neutron cross sections with necessary accuracy in the mentioned energy range. Today a few of such installations are designed and may be used (e.g. in LANL, ORNL), but they need very large costs. There is in existence the alternative way to get the high accuracy neutron cross sections: to use the neutron filtered beam technique at the existing research reactors. Surely, this technique has its own positive and negative sides and needs the financial costs, too, if you have to purchase the high enriched isotopes for filter components. However, with good optimization of all filter components and careful evolution of neutron cross section measurement methods, this neutron filtered beam technique may be widely used at the many of the existing research

---

<sup>\*</sup>Corresponding author, e-mail address: ogritzay@kinr.kiev.ua

reactors to provide the measurements of neutron cross sections with the accuracy, needed for today.

## NEUTRON FILTER BEAMS AT THE KYIV RESEARCH REACTOR

The KRR is a tank-type reactor with beryllium reflector and light water both as moderator and coolant. The core is an assembly of fuel rods, which are 36% enriched with uranium-235. The nominal thermal power is 10 MW. Neutron flux in the core is about  $10^{14}$  n/cm<sup>2</sup>s. The KRR has ten horizontal tubes, now three of them are employed in experimental investigations with using of the neutron filtered beam technique.

The main idea of neutron filter technique is the use of large quantities of matter which nuclei have the deep interference minima in their total neutron cross sections. By transmitting reactor neutrons through thick layer of such material, one can obtain the quasi-mono-energetic neutron lines instead of white reactor spectrum. To get only one quasi-mono-energetic neutron line (so-called, neutron filter beam with high purity) the composition filter is usually used. This composition filter consists of the “main filter material” and additional materials, for which resonance maximima in their total neutron cross sections coincide with interference minima for filter material, with the exception of the most deep interference minimum energy.

The basic demands to neutron filter beam are the following:

1. The purity of the main energy line in neutron spectrum has to be as much close to 100% as possible.
2. Neutron intensity has to be the most possible value, sufficient to obtain the necessary accuracy in experiment.
3. Construction and composition have to provide the minimal possible gamma-background.
4. In necessary cases the construction and composition have to allow the increase or reducing of the base line width without essential worsening of filter quality.
5. The amount of enriched isotopes in filter components has to be minimum necessary.

The wide set of natural elements and enriched isotopes are used as components for neutron filters in the Neutron Physics Department (NPD) at KRR:

- Natural elements: Si, Al, V, Sc, S, Mn, Fe, Ti, Mg, Co, Ce, Cr, Rh, Cu, B, Cd, LiF.
- Enriched isotopes: <sup>52</sup>Cr (99.3%), <sup>54</sup>Fe (99.92%), <sup>56</sup>Fe (99.5%), <sup>57</sup>Fe (99.1%), <sup>58</sup>Ni (99.3%), <sup>60</sup>Ni (92.8% – 99.8%), <sup>62</sup>Ni (98.04%), <sup>80</sup>Se (99.2%), <sup>10</sup>B (85%), <sup>7</sup>Li (90%).

Availability of such wide set of materials, especially enriched isotopes, allowed to create in the NPD the unique set of neutron filters, providing more than ten neutron lines in the energy range from thermal energy to several hundred kilo-electron-volts, intensity of such lines may reach  $10^6$  –  $10^8$  n/cm<sup>2</sup>s [1, 2], and this is much more than any other method (time of flight or others) can ensure. The wide set of filter materials also allows us to modify filter parameters (purity, intensity, width, etc.) subject to the given research task. Through expensiveness of high enriched isotopes, the natural elements or enriched isotopes available in the NPD are usually considered as components of new or improved filters.

Energies and comparative intensities of the neutron filter beams used for fundamental investigations, carried out in the NPD, are shown in Figure 1. Covered energy region is from thermal energy (this filter is not presented in figure) to 149 keV.

As an example, the filter components (g/cm<sup>2</sup>) used by us for the forming of some filtered neutron beams are presented in Table 1.

**Table 1.** The filter components ( $\text{g}/\text{cm}^2$ ) used for the forming of the filtered neutron beams.

2 keV filter						
$^{10}\text{B}$ (85%)	$^{45}\text{Sc}$	$^{60}\text{Ni}$	$^{54}\text{Fe}$	S	$^{59}\text{Co}$	$^{27}\text{Al}$
0.2	104.6	80.2	39.35	56.0	26.7	0.54
3.5 keV filter						
$^{10}\text{B}$ (85%)	$^{54}\text{Fe}$	$^{60}\text{Ni}$	S	Cd	$^{27}\text{Al}$	
3.15	170.7	146.2	36.7	0.865	1.349	
24 keV filter						
$^{10}\text{B}$ (85%)	S	Fe	$^{27}\text{Al}$			
0.95	16.35	236.1	99.86			
133 keV filter						
$^{10}\text{B}$ (85%)	$^{52}\text{Cr}$	$^{58}\text{Ni}$	$^{60}\text{Ni}$	Si	$^{27}\text{Al}$	
0.2	95.94	194.06	3.1157	93.08	0.54	

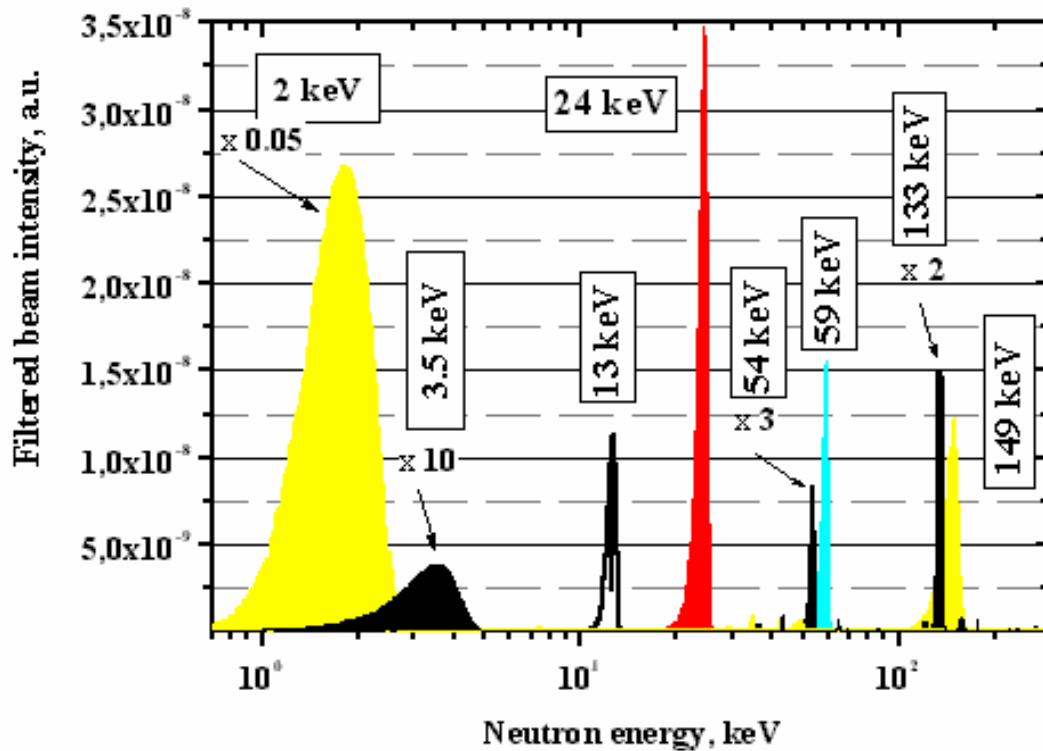

**Fig. 1.** Neutron filters used in the NPD for fundamental investigations.

## THE NEUTRON MEASUREMENT TECHNIQUES FOR FUNDAMENTAL INVESTIGATIONS IN THE NPD

As it was noted above, now three of ten horizontal tubes of the KRR are employed in experimental investigations with using of the neutron filtered beams. Today four neutron measurement techniques are developed in the NPD and used for fundamental investigations: on the filtered beams. There are the following directions:

- 1) total neutron cross sections;
- 2) neutron scattering cross sections;
- 3) angle distribution of scattering neutrons;
- 4) neutron capture cross sections.

According to the formulated task, the filter components (even for filters with the same energy), experimental equipment installed on the KRR horizontal channels, shielding, etc. may be very different in configuration and size, but four main systems are always present:

- 1) system for forming of filtered neutron beams;
- 2) system of radiation shielding;
- 3) sample management system;
- 4) neutron detector and counting system.

The forming system includes the elements of beam collimation and neutron filtration on the way from reactor core to detector. The preliminary forming of necessary beam geometry is realized with two iron and boron carbide collimators. Further beam forming takes place in the first three discs of shutter and in outer collimator. In the order lead, textolite and mixture of paraffin with  $H_3BO_3$  are used as material for these collimators. The collimation system provided beam narrowing to necessary diameter. The elements of neutron filtration system take place in the first three disks of shutter and in the outer collimator (see Figure 2).

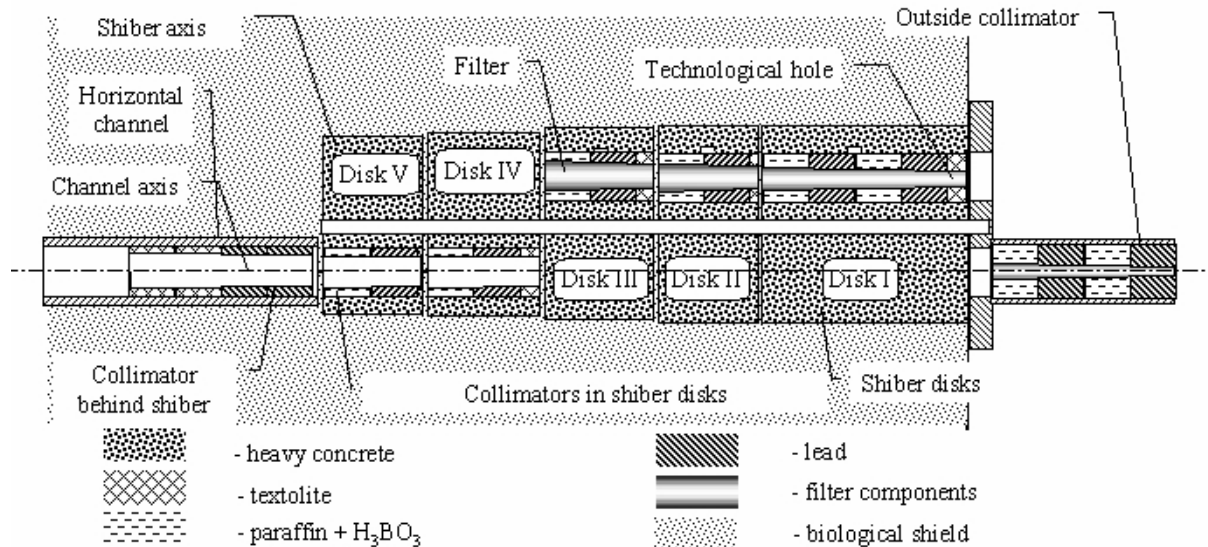
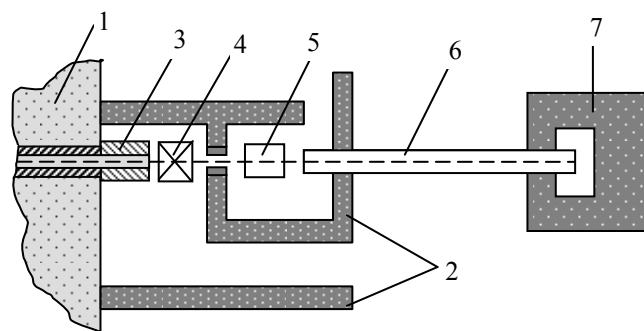

**Fig. 2.** The elements of neutron filtration system in horizontal reactor channel.

To facilitate and quicken the procedure of filter changing, special containers for filters were made. These containers are tubes from stainless steel, length of them are equal to length

of beam shutter disks. Collimation materials (ordinarily paraffin with  $H_3BO_3$  and lead, taking turns) and filter components are inserted in these tubes.

The systems of radiation shielding on the two horizontal channels (designed for total and scattering cross section measurements) are made of two boxes. The first and second boxes are separated by a shielding wall (thickness 40 cm on the 8<sup>th</sup> HC, thickness 70 cm on the 9<sup>th</sup> HC), in which the Pb collimator (internal diameter 2 cm) is placed. The outside collimator with additional elements for beam collimation and neutron filtration and the device for sample removing are placed in the first box; detectors, their power supply electronic blocks and monitoring equipment are located in the second box. Also in the second box there is the device for scattering sample removing. Walls and ceilings of boxes on the both channels were made from metal containers filled by metal scrap, water and 5-7% boric acid. Both boxes on these different channels have different sizes, disposition of entrances and thickness of walls.



**Fig. 3.** Scheme of system of radiation shielding on the 8-th horizontal reactor channel. 1 – biological shielding; 2 – radiation shielding of installation; 3 – outside collimator; 4 – device for sample removing; 5 – neutron detector; 6 – tube for beam conducting up to neutron catching; 7 – neutron beam catching.

The system of radiation shielding on the last used channel (the 2<sup>nd</sup> HC designed for neutron capture cross section measurements) is made of two screens. The external screen is made of paraffin with lithium hydride ( ${}^6LiH$ ), and the internal one – of lithium carbonate ( ${}^6Li_2CO_3$ ). Lithium, enriched by  ${}^6Li$  to 85% was used in both screens. Scheme of the radiation shielding system on the 2<sup>nd</sup> HC and the target irradiation position are shown in Figure 4.

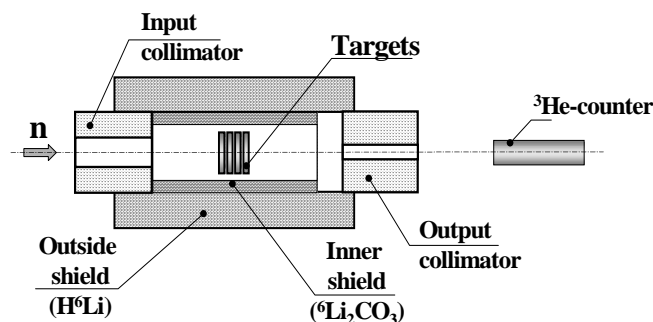

**Fig. 4.** Scheme of the radiation shielding system on the 2<sup>nd</sup> HC and the target irradiation position.

Both sample management system and neutron detection system depend on kind of task formulated in experiment.

For measurement of total neutron cross section we use 2 types of sample management systems. On the 8-th HC it includes centering tube, three sample holders, one holder of cover, holder control levers and electric motors with control blocks. Simultaneously three samples can be loaded into this system and placed to the beam. The sample management system on the 9-th HC consists of two cylindrical devices "A" and "B", in each of them four samples can be inserted. The devices "A" and "B" revolve independently, so simultaneously two samples can be placed on the beam. The management systems for experimental samples provide the establishment of the samples on neutron beam with definite alternation at any sequence and combination.

The detection and neutron registration systems on the both HC include: neutron counter, electronic blocks, personal computer and communication lines about 50 m long between spectrometric installation and measuring room.

For neutron energies equal and less than 12 keV, the helium-3 detectors: a) CHM-37 (diameter – 18 mm, length - 500 mm, gas pressure – 7 atm); b) LND 2527 (diameter – 25.4 mm, length – 386.84 mm, gas pressure – 20 atm) are used in the neutron total cross section measurements. For neutron energies more than 12 keV, the proportional hydrogen recoil counters: a) CHM-38 (Gas Filling – 90% H<sub>2</sub> + 9.56% CH<sub>4</sub> + 0.44% <sup>3</sup>He<sub>2</sub>, diameter – 30 mm, length - 300 mm, gas pressure – 4 atm); b) LND 281 (Gas Filling – H + CH<sub>4</sub> + N<sub>2</sub>, diameter – 38.1 mm, length – 254.0 mm, gas pressure – 4.3 atm) are used. Sometimes, for neutron energy 12 keV, the both types of detectors are used. As a rule, detector is installed along the neutron beam.

For measurement of the neutron scattering cross sections the sample management system consists of three devices "A", "B" and "C", which run independently. Devices "A" and "B" are usually used in the total cross section measurements and they are described in detail above. In elastic scattering measurements, one of these devices ("A" or "B") was used for location of polyethylene sample to cut off a neutron beam. Measurements with polyethylene sample are necessary to determine background counting rate. Device "C" was constructed specially for the elastic scattering measurement. It looks like a cross made of two tubes. The diameter of the tube, located along the neutron beam, is 60 mm; the diameter of the tube perpendicular to beam, is 100 mm. Five sample holders are placed in this tube. The sample holder is a thin-walled tube (without top and bottom), made from aluminium alloy, set in thin rod. The inner diameter of the holder is 30.45 mm, so solid samples have a diameter of 30.40 mm. The stand with holders (samples) moves perpendicular to the beam, installing a measured sample in the centre of beam. The sample position is fixed with an accuracy of 0.1mm and checked by the control system of the device "C". To reduce scattering on air, vacuum about 0.01 Torr is maintained inside of "C".

The detection and neutron counting systems included: neutron detector, electronic blocks, personal computer and communication lines about 50 m long between the spectrometric installation and the measuring room. The neutron detector, consisted of the <sup>3</sup>He counters (58 units), was located just above the carbon samples. The He-3 counters (CHM-37, 7 atm, diameter =18 mm, L=50 cm) were placed in five layers (12 or 11 units in each layer). The detector was covered by cadmium sheet with thickness 0.5 mm; it was protected then by borated polyethylene blocks.

Cleaner pictures of the experimental facility, relating to the scattering chamber, and samples (device "C") and the neutron detection system (assembly of the <sup>3</sup>He counters with radiation shielding), can be seen in Figure 5, where the part of the MCNP simulation is shown.

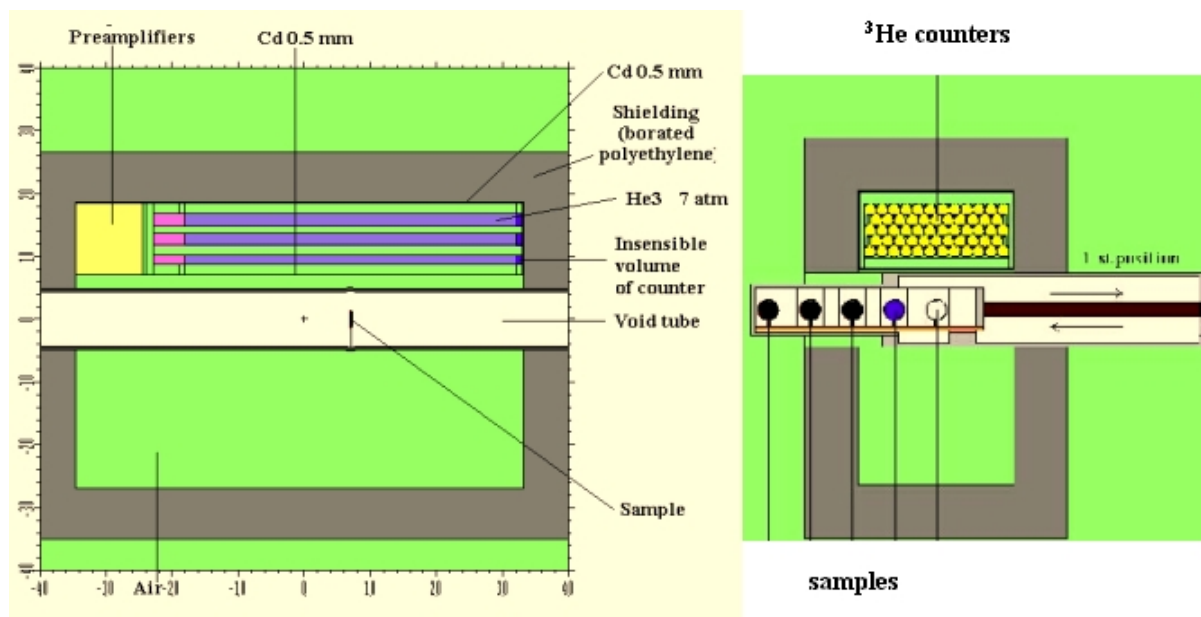

**Fig. 5.** Disposition of the He-3 counters and samples (vertical cross section). In the left - along neutron beam, in the right - perpendicular to beam.

For measurements of the angle distribution of scattering neutrons two spectrometric installations have been created IASD-1 and IASD-2 (Installation for Angle Scattering Distribution).

The first of them was designed for measurements at one angle in the range from  $30^\circ$  to  $150^\circ$ . The vacuum chamber of the IASD-1 installation is an aluminum cylinder with 130 mm height and 214 mm diameter; its butt-ends are closed by flanges. One of them is the foundation for an electromechanical device for investigated samples; the second has the special configuration that provides the identical thickness of aluminum on the way of scattered neutrons from the sample to detector; it is due to the thin-walled semi-cylinder lug on the flange, the center of which coincides with the center of sample-scatterer, that is on the beam. Neutron guides have 74 mm internal diameter and 850 mm length. The butt-ends of these guides are closed by aluminum diaphragms with 1mm thickness. The axis of chamber occupies the horizontal position relative to the beam. The scheme of chamber with the electromechanical device and the position of neutron detectors is presented in Figure 6.

The device for setting of samples, as it can be seen from Figure 6, has the shape of five-ray star. At the end of rays (65 mm distance from the center) on thin spokes the holders for samples are set. The holder is ring-shaped with 30.4 mm diameter, 6 mm width and 0.1 mm thickness. For prevention of sample fall-out, the holders have 0.5mm welt and from other side a sample is fixed in a holder with a spring clamp. The centers of samples inserted at holders are at the 75 mm distance from the rays of five-ray star, to prevent the influence of installation structure components on the experimental results.

Every sample at their transposition occupies the fixed position on the axis of chamber. The special reducing gear of "maltese cross" type is used for the transmission of engine axis rotation to the rotation of five-ray star with samples and that provides the fixing of samples position on the neutron beam.

At right angle to the surfaces of flange in a horizontal plane there is set the metallic slab for neutron detectors placing. Detectors can be set under any angle in relation to the axis of neutron beam, as each of them is the separate construction. A mobile platform is also foreseen

with set on it of one detector; it is possible to remove this platform on the slab at any angle within the limits of  $30^{\circ}$ - $150^{\circ}$ . Direction of axis over which a platform is rotated coincides with the center of sample that is at the beam. Due to this, it is possible to conduct the measurements under necessary angles with the same detector. It enables to check up the isotropic dispersion of scattering neutrons on the certain sample.

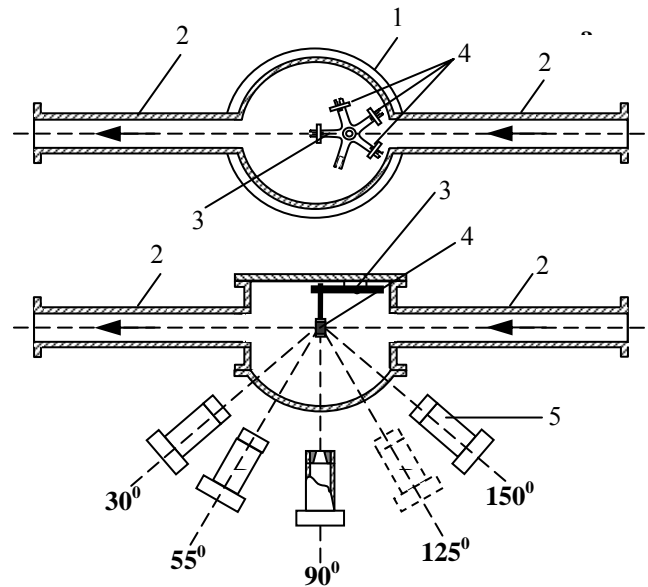

**Fig. 6.** Installation IASD-1: vacuum chamber scheme. 1 – chamber; 2 – neutron guide; 3 – sample changing gear ; 4 – sample-scatterer; 5 – neutron detector with preamplifier.

For registration of the scattered neutrons, five specially designed detectors were used. Every detector is the assembly of seven helium counters CNM-17 (18 mm diameter, 220 mm length, 7 at pressure), which works with one preamplifier. For every assembly of counters the units were picked up with the identical gas amplification, so that no expansion of helium peak took place in spectrums. These assemblies have the individual radiation shielding as the cylinder thin-walled container (100 mm external diameter, 300 mm length) filled with the boron carbide. Internal diameter in a container for detector assembly was 65mm. Detector assemblies were placed on the slab so that the axis of the assembly was in a horizontal plane on one line with the center of the sample on the neutron beam.

The IASD-2 installation provides the possibility of the neutron spectrum measurements additionally under the angles  $15^{\circ}$  and  $165^{\circ}$ . At its construction a purpose was in mind to remove as much as possible the experimental sample from construction elements placed in the vacuum chamber. The schematic draw of IASD-2 installation is presented in Figure 7.

IASD-2 was planned for the simultaneous operation with four samples. A few words about the device for holding the samples:

- its elements are mounted directly on „maltese cross“;
- holders of samples as rings (30.4 mm internal diameter) with cut out  $90^{\circ}$  sector are fixed on spokes with 2 mm diameter and 80 mm length;
- cuts in rings were directed to the side of detector platform, that provides the absence of construction material on the way of neutrons from the sample to detector;

- spokes of holders are twisted in guides, that are inserted into the sockets and are fixed there with the special spring clamps;
- the assemble ring-spoke-guide, as a single whole, can be easily taken out or inserted into the sockets, that allows quickly replace the samples in holders.

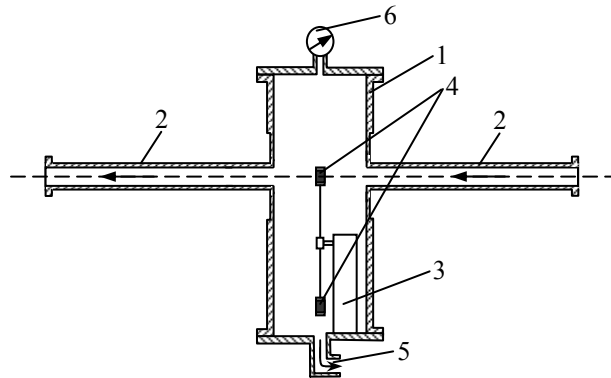

**Fig. 7.** Schematic view of vacuum chamber of IASD-2 installation: 1 – chamber; 2 – neutron guide; 3 – electromechanical device; 4 – sample-scatterers; 5 – vacuum socket; 6 – vacuum gage.

For neutron registration, the detectors on the base of hydrogen counters LND-281 are foreseen and also on the base of helium counters LND-2527. The set of detectors was created on the base of these counters, each of them was the unified construction of a counter and preamplifier. These constructions, as well as preamplifier itself, were developed and manufactured in our department.

The control systems and electronic measuring devices of both installations are identical (see Figure 8).

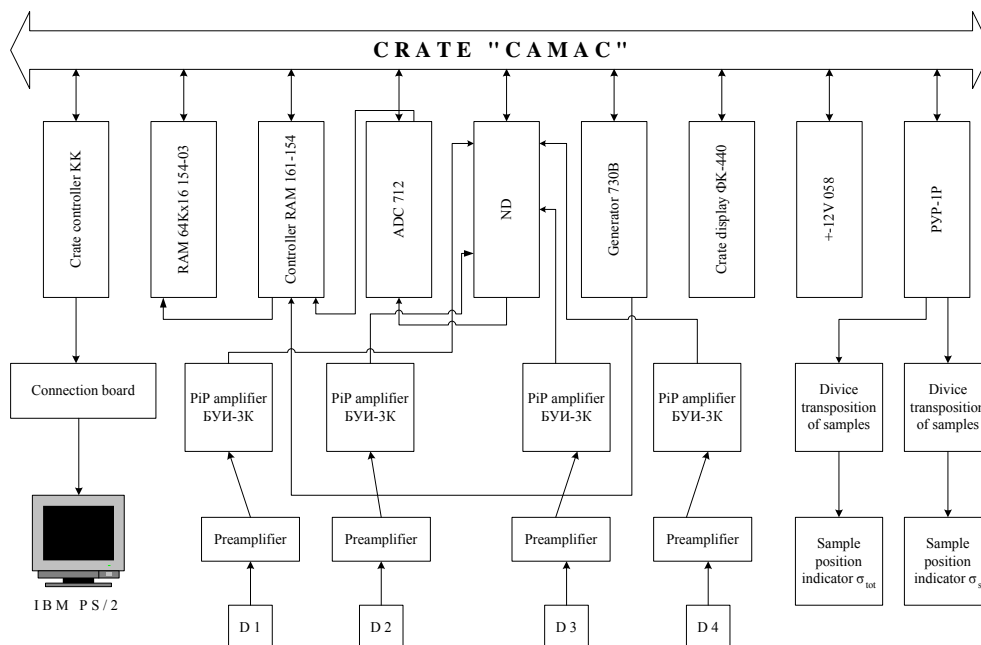

**Fig 8.** Flow block of spectrometry section in installation for differential cross section measurements.

In the electronic measuring section the special block of detector numbering (DN) enters except for traditional electronic blocks (preamplifier, main amplifier and digital converter). Signals from every detector at first enter this block, where the number of detector is appropriated to them, and already then it goes to digital converter. The management of this system during measurement is executed by the special program ZERKIN-3.

For measurement of the neutron capture cross sections by activation method as usual the illuminated targets are set up in special container (see Figure 4) as a single pile from several disks, dispose one by one. Exposition of several disks, not just one, allows us to take into account an effect of a resonance self-shielding in material.

The neutron flux at the target place is defined using the  $^{10}\text{B}(n,\alpha\gamma)^7\text{Li}^*$  reaction. The neutron flux is defined by area of the full absorption peak of gamma rays with 478 keV energy (the excited state of  $^7\text{Li}$ ). The B-10 target used to define the neutron flux value, was made of the boric powder, enriched by  $^{10}\text{B}$  isotope. The target is placed inside the container with 28 mm diameter. The container was made of CAB-1T aluminum alloy; the front and back walls were of 0.2 and 0.3 mm thickness, respectively. The thickness of a boric sample was 1 mm. Ratio of boron – 97.1%; enrichment by  $^{10}\text{B}$  – 85%. Flux was controlled every hour during 1000 s.

During all irradiation time, the permanent monitoring of neutron flux is realized by neutron spectrometer with  $^3\text{He}$ -counter. The  $^3\text{He}$ -peak area is used as weigh function for averaging of irradiation flux. The neutron flux, taken from the measurements due to the boric target before and after exposition, is averaged by this weight function, and the average neutron flux is determined during total time of the exposition.

The target activity is measured after irradiation in so-called “clean” zone, where the background conditions are much better. Gamma spectra of the irradiated samples are measured with gamma-spectrometer on the base of Ge(Li)-detector. The measured sample is located at the 5 cm distance above the detector cap. The measurements are carried out by series. In series each of samples is measured twice: «face» down and «face» up. A «face» is the sample side, turned to incident neutrons during irradiation. Before and after each measurement series the background spectrum is controlled.

## **SOME EXPERIMENTAL RESULTS OBTAINED AT THE KYIV REASEARCH REACTOR**

Using experimental techniques described above, a set of results on interaction of neutrons with nuclei were obtained at the neutron filtered beams of the KRR. In the most cases the accuracy of experimental values was higher than those obtained in this energy region by other authors. For example, accuracy of neutron capture cross section for the  $^{181}\text{Ta}(n,\gamma)^{182}\text{Ta}$  reaction at the neutron energy 2 keV was 3.5% [1], accuracy of the total neutron cross section for carbon in the energy region from 2 to 149 keV may be better than 1% [2, 3], accuracy for the scattering neutron cross section in the same region may be better than 3% [3, 5]. To illustrate the last two statements a part of the obtained results, presented earlier in [2-5], is shown in Figures 9 and 10.

As it can be seen from these figures, for some values of the total neutron cross sections the accuracy is close to 0.3%, of the scattering cross section – up to 0.5%.

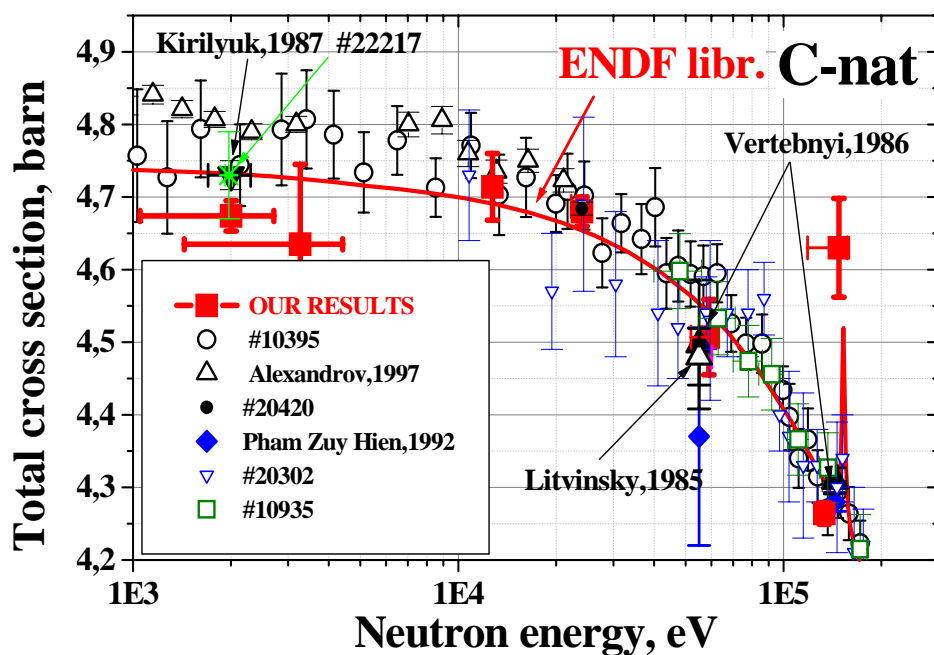

**Fig. 9.** Experimental results for the total neutron cross sections on carbon, obtained in NPD using transmission method [2, 3] and data from ENDFB/6 and EXFOR libraries.

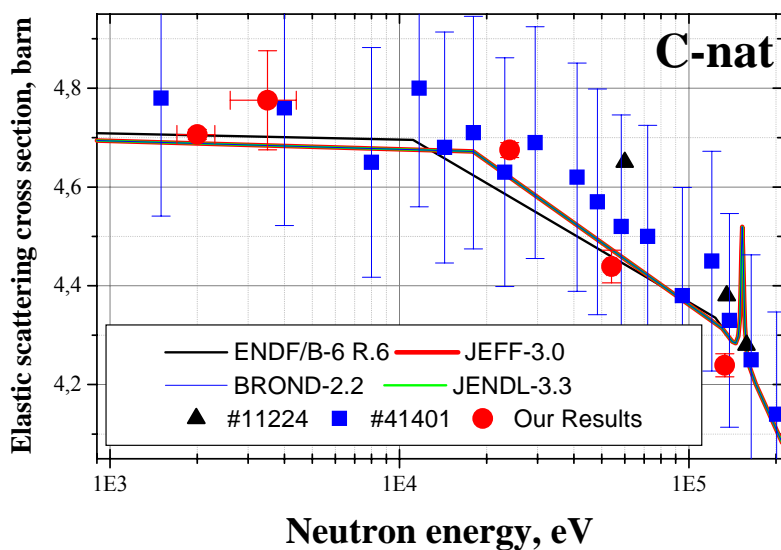

**Fig. 10.** Our results of the neutron scattering cross sections for natural carbon in the energy range 2 -133 keV [4, 5], the known experimental data from database EXFOR/CSISRS and ENDF libraries.

## REFERENCES

- [1] O.O. Gritzay, V.A. Libman, A.V. Chyzh “Cross Section Measurement of the  $^{181}\text{Ta}$  (n, $\gamma$ ) $^{182}\text{Ta}$  Reaction at the Neutron Energy 2 keV”, *Proc. of the International Conference Current Problems in Nuclear Physics and Atomic Energy*, May 29 - June 3, 2006 Kyiv, Ukraine, p. 569.
- [2] O.Gritzay, V.Koloty, N.Klimova, O.Kalchenko, M.Gnidak, P.Vorona “Precision Neutron Total Cross Sectional Measurements for Natural Carbon at Reactor Neutron Filtered Beams ”, *The Twelfth International Symposium on Reactor Dosimetry*, May, 2005, Gatlinburg, TN, USA.
- [3] O.Gritzay, V.Koloty, N.Klimova, O.Kalchenko, M.Gnidak, P.Vorona “The total neutron cross section for natural carbon in the energy range 2 to 148 keV”, *International Conference on Nuclear Data for Science and Technology "ND2007"*, April, 2007, Nice, France, Program and Abstracts.
- [4] O. Gritzay, M. Gnidak, V. Koloty, O. Korol, V. Razbudey, V. Venedyktov, J. Richardson, K. Sale “The Neutron Scattering Cross Sections for Natural Carbon in the Energy Range 2-133 keV”, *47<sup>th</sup> INMM Annual Meeting*, July 16-20, 2006, Nashville, Tennessee, USA. Program and Abstracts.
- [5] O.O. Gritzay, M.L. Gnidak, O.I. Korol, V.F. Razbudey, V.M. Venedyktov “Investigation of the Scattering Cross Sections of Neutrons on Carbon Nuclei at the Reactor Filtered Beams”, *Proc. of the International Conference Current Problems in Nuclear Physics and Atomic Energy*, May 29 - June 3, 2006 Kyiv, Ukraine, p. 541.